



Buoyancy Compensator

Owner's Manual



Introduction

Thanks for Choosing Zeagle!

We value your decision to invest in a Zeagle Buoyancy Control System. Please have your authorized Zeagle Dealer familiarize you with the operation and care of your new Zeagle Buoyancy Compensator* (BC) and go over your Owner's Manual with you. Have your Dealer sign the appropriate line on the service record at the end of this manual, after he has performed this service. Before you use your BC for the first time, be sure your Dealer has performed the Dealer prep check list. Please save and refer to this Owner's Manual from time to time to enable you to fully understand and benefit from this fine product.

SCUBA Diving is an extremely enjoyable pastime when done with proper training, good equipment, and knowledge of both your equipment and your diving environment. **This Zeagle Buoyancy Control System is intended for use only by individuals practicing safe diving principles.**

*Buoyancy Compensator (BC) and Buoyancy Control Device (BCD) are synonymous for the same piece of SCUBA diving equipment.



Contents

Introduction	1
Warranty Information	3
General Information and Specifications	4
Function of the Zeagle System.....	7
Fitting and Assembly	9
Double Tank Mounting Options	12
Pre-dive Assembly and Inspection	15
Donning Procedures.....	19
Diving with the Zeagle System	20
Emergency Procedures	21
Maintenance	23
Available BCD Accessories	24
Service Record	25



Warranty Information

WARNING

Owner's Responsibilities

- Zeagle Systems, Inc. requires that the end user of this system be certified by a nationally or internationally recognized SCUBA certification agency and adequately trained in its use by a certified SCUBA instructor with thorough knowledge and experience in the use of Zeagle Systems, Inc. equipment.
- An annual inspection performed by an authorized Zeagle Dealer is required for the safe operation of this system.
- **Your Zeagle BC is NOT a personal flotation device and should not be used as a life jacket. The BC does NOT guarantee a heads up position of the wearer at the surface.**
- All emergency procedures should be practiced periodically in shallow water (10 feet or 3 m) to maintain preparedness in the event an actual emergency should occur.
- The owner is ultimately responsible for completing the Warranty Registration by filling out the form included with the BCD and mailing it to Zeagle Systems, Inc., or by going to the Product Registration page at www.zeagle.com. One of these methods must be completed within 30 days of purchase.
- For assistance with preparation, questions or service, contact your local authorized Zeagle Dealer or Zeagle Systems, Inc.

IMPORTANT

LIMITED LIFETIME GUARANTEE TO THE ORIGINAL OWNER

Your BC is guaranteed against defects in materials and workmanship. This guarantee does **not** cover damages from accident, abuse, neglect, alterations, improper usage, normal wear & tear or failure to provide reasonable care. To validate your warranty you must fill out and return your warranty registration by regular mail or e-mail, within 30 days of purchase. All warranty claims will be handled through Zeagle, or an authorized Zeagle Dealer.



General Information and Specifications

IMPORTANT

This Buoyancy Compensator's Owner's Manual contains important safety, maintenance, and operation information.

Read this manual thoroughly before diving.

Important information on the assembly, operation, and maintenance of your BC is designated throughout this manual with the "IMPORTANT" graphic and the symbol shown above.

This owner's manual also uses the following "WARNING" graphic and symbol to designate that special attention needs to be given to the manual, otherwise, a potentially hazardous situation which, if not avoided, may result in injury or death.

WARNING

WARNING

SCUBA diving is an adventuresome activity and some risks are involved. Please be sure that you and your dive partner have current certifications and follow all of the recommendations of your certifying agency and that all equipment is used and maintained according to the manufacturer's recommendations. Failure to follow these guidelines can result in serious injury or death.



General Information & Specifications

SCUBA Cylinder Selection and Configuration

Your over-all buoyancy depends on a combination of the buoyancy of all your diving equipment added to your own body's buoyancy. The Zeagle System is designed to work with a variety of tank sizes and configurations.

WARNING

Failure to comply with the following information may result in an improper buoyancy configuration. You must maintain neutral buoyancy while diving to prevent injury or death.

IMPORTANT

The maximum single and double cylinder size specifications (in liters) for the BC is found on a tank pictogram on the warning label. This label is found on the BC, inside the vest. If the double cylinder pictogram has a "XX" in it, then the BC has been designed for single cylinder use only. If the single and double cylinder pictograms have numbers in them, then the BC has been designed for either single or double cylinder use. The number in the pictogram indicates the largest cylinder size recommended, in liters.

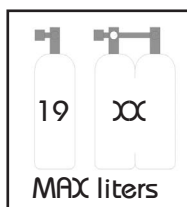

Tank Pictogram

Cylinder **dimensions** and **capacity** are two quantities which are important to understand when configuring your equipment. Cylinder dimensions are the actual, outside dimensions of a SCUBA cylinder (also called the tank). Zeagle BC's are designed specifically for SCUBA cylinders which have a maximum diameter of 8 in (20.3 cm) and maximum height of 31 in (78.7 cm). Consult your local authorized Zeagle Dealer if you have any questions regarding cylinder **dimensions**.

Cylinder **capacity** is the volume of the SCUBA cylinder. When expressed in cubic feet, the volume is given for compressed gas. When expressed in liters, the volume is given for the actual volume of the cylinder based on the interior dimensions of the cylinder (water capacity). Zeagle Systems, Inc. maximum recommended cylinder capacity is 120 ft³ (19 liters). Once again, if you have a question, consult your local authorized Zeagle Dealer.



General Information and Specifications

Surface Buoyancy of BC's

Your BC's buoyancy, has been rated by Zeagle Systems, Inc. Buoyancy figures were measured in fresh water at sea level, and were rounded down to the nearest pound. For buoyancies listed in the metric system, buoyancy is measured in multiples of 10 Newtons, then rounded down to the next lowest multiple.

The buoyancy of your BC is printed on a label, located on the bladder assembly, as shown on page 8. A typical label for a BC will look like the example below. This particular label indicates that the bladder assembly is rated at 19 kg (44 lbs) buoyancy.

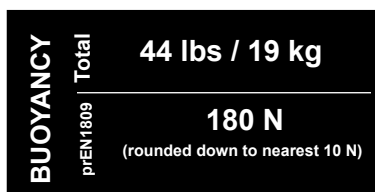

Operating Temperature Range

Table 1.0

Air	-4° to +122° F	-20° to +50° C
Water	+28° to +104° F	- 2° to +40° C



WARNING

Special Instruction in cold water diving methods, and the specific use of this product is required prior to cold water diving (temperatures below 10° C / 50° F). This instruction is beyond the scope of this Owner's Manual. Diving without this instruction could result in injury or death. Consult your SCUBA instructor for this instruction prior to using this product in cold water.

Shelf Life

The shelf life for a new, unused BC when deflated and stored in a dry place at room temperature, with no exposure to ultraviolet (UV), light is seven years. Refer to page 23 for Storage and Post Dive BC Cleaning information.



Function of the Zeagle System

The Zeagle Buoyancy Control System

The function of the Zeagle buoyancy control system is to add to your diving enjoyment. It is designed to provide you with a comfortable way of “wearing” your SCUBA system, a resting platform while on the surface, and an easy means of controlling your buoyancy while diving.

Vest

The vest portion of the system should fit so that it wraps partially around the front of the diver. See the Illustration on page 14. You should be able to tighten the waist strap so that the vest fits quite snugly around the waist, in order to prevent the BC from shifting during the dive. If you can draw the two sides of the vest together and the fit is still not snug, you need a smaller size vest. If the Vest is uncomfortably tight when the fully extended strap is fastened, you need a larger vest. The ZENA lady's BCD is different from other models, in that the vest portion is fastened to the body of the BCD with two adjustable straps and is closed by a front zipper. The ZENA is worn so that the top strap is at the narrowest part of the waist, above the hips.

Side Panels (Cummerbund)

The side panels should fit around the waist (top of the hip) NOT over your rib cage or diaphragm, with at least a four inch overlap on the touch fastener (Velcro) closure. The side panels are attached using six (6) plastic screw fasteners, and can be adjusted by moving the side panels to a different set of grommets on the vest section. See the Illustration on page 9. **It is imperative that the BC not be worn too high on the body** as this will create an undesirably high center of gravity and could restrict the ability of your diaphragm to move freely, resulting in discomfort or shortness of breath. Side Panel Extenders are available.

Shoulders

Length of the shoulder strap depends on personal comfort and the length of your torso. Take into consideration different suits you may be wearing with the system, and be sure to allow enough length so the pack may be worn low as described above. The sternum strap should be just above the breast line as shown on page 14. You should easily be able to reach the quick release buckles. The sternum straps have high and low attachment loops. The BCD leaves the factory with the sternum straps attached to the higher loops. If this position puts the strap too close to the neck or the strap is covering a Dry Suit inflator, then the strap can be moved to the lower attachment points.



Function of the Zeagle System

Bladder Assembly

The bladder assembly attaches to the vest section via four stainless steel slotted fasteners sewn to inner edge of the bladder assembly. Each of these slotted fasteners slides over the two Single-Tank Bands. This fastenes the Bladder to the Tank Bands. If the BC is to be used with double tanks, then the single tank bands are removed and the optional double tank straps (p/n 7281M) slide through the webbing slots at the back of the vest just as the removed single tank bands did (see cylinder band illustration on pages 10 thru 13). The stamped metal ends of the straps are threaded through the eye of the metal tabs on the Bladder Cover (see illustration below). There are two plastic buckles on the Bladder Cover Winglets, which clip over the weight pockets to hold the buoyancy forward. *Do not dive with the two forward small side release buckles detached!* The shoulder straps should pass through the collar at the top of the bladder assembly.



WARNING

Do NOT dive with the two winglet side release buckles detached!

The Tank Bands and the optional double tank straps go through the same backplate webbing slots.

Shoulder strap goes through the collar

Surface Buoyancy Label Location

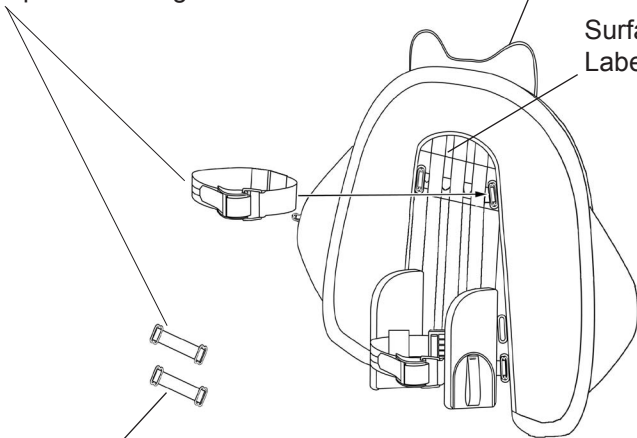

Optional double-tank Straps are required **IF** Double Tanks are mounted to the BC.
p/n 7281M (2 required)

The Winglet Side Release Buckles **must** be attached to the vest.



⚠ WARNING

NEVER breathe from the bladder assembly. The bladder assembly was not designed as an auxiliary air source and may contain harmful contaminants, which if inhaled, may cause injury or death.

Fitting and Assembly

Adjusting the Side Panels

1. Using two coins, unscrew the plastic barrel-screw fasteners.
2. Move the side panel to different set of grommets on vest and reinstall.

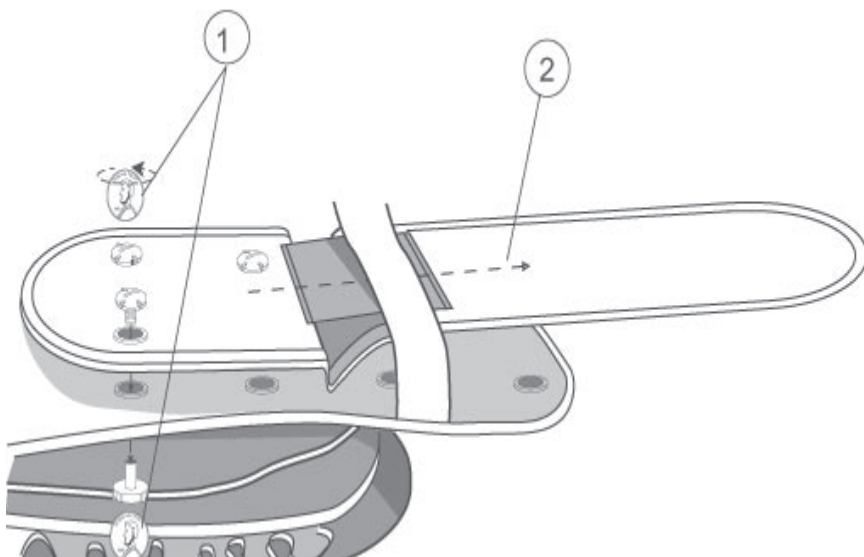

3. Note that one extra plastic barrel-screw is installed in an unused grommet hole when the BCD leaves the factory. This extra screw can be used if one is lost.



Fitting and Assembly

Threading The Standard Single Cylinder System

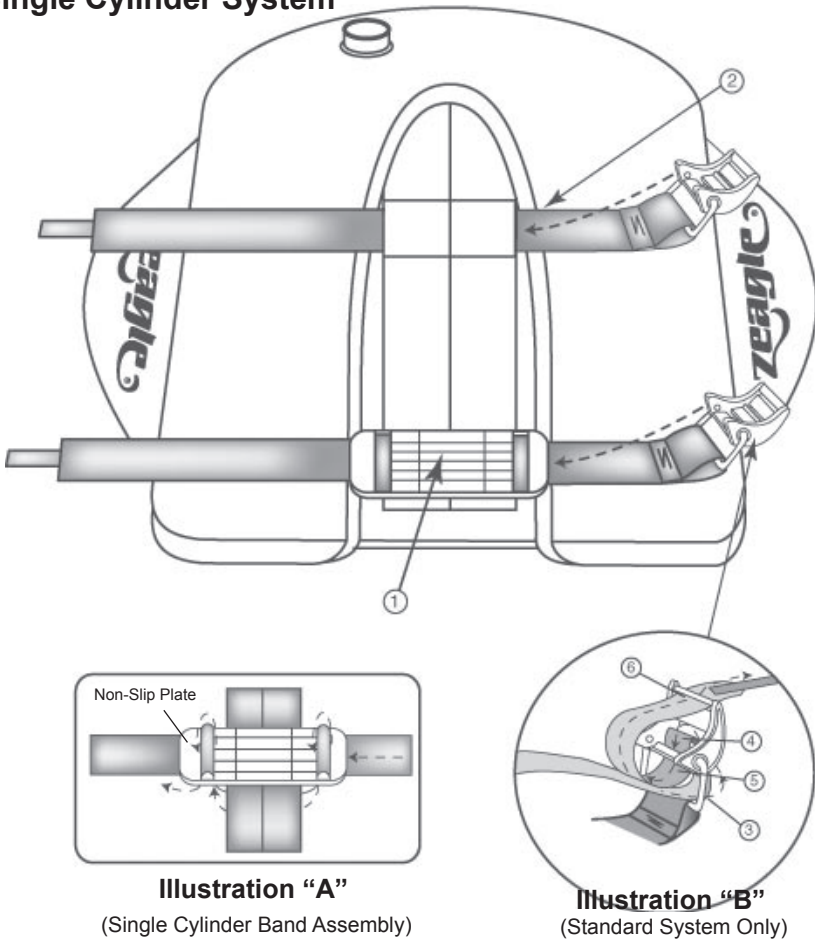

Note: Tank bands expand and lengthen when wet. For this reason, you will get a tighter fit if you make your initial adjustments with tank bands that have been wet for at least 20 minutes.

1. Thread the lower cylinder band through the non-slip plate and then under the bottom center backplate straps as shown in Illustration "A."
2. Thread the upper cylinder band under the top center backplate straps on BC as shown in "A".
3. After threading the bands through the BC, thread the bands through the buckle as per Illustration "B".
4. Threading instructions are also embossed on the side of the plastic buckle.
5. After Looping the webbing through final slot in buckle, check to be sure that your cylinder is lined vertically on the BC. "Cam" the buckle over for extra tension.
6. Lock the buckle by engaging the Velcro material on the tank band.



Fitting and Assembly

Threading The Standard & Quick Release System On A Twin Cylinder Back Plate

Standard System

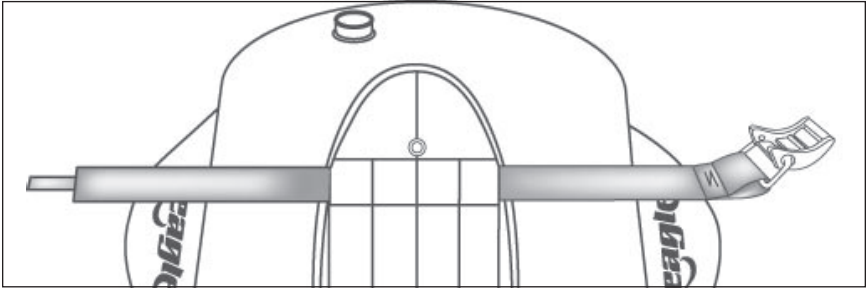

Optional Quick Release System

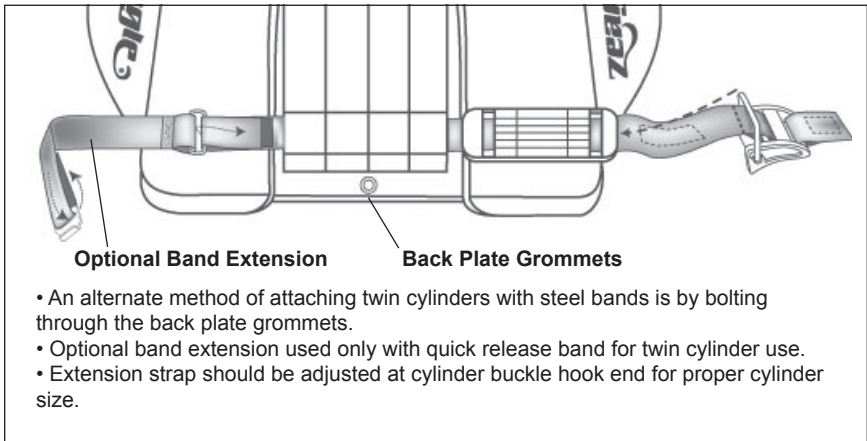

There are only minor differences on a twin cylinder model. The rubber “nonslip” plate should be completely installed on the bottom band opposite the touch fastener (Velcro) material on the band, before inserting the band under the webbing on the pack. The bands go under the vertical webbing on the back plate. If your system has only two pieces of vertical webbing, it is not a twin cylinder model and should not be used with twin cylinders. If you are setting up a double pack for single cylinders, please note that the single size cylinder bands only go under the center 4 inches (10.2 cm) of vertical webbing on the back plate and the rubber plate is installed as illustrated on pages 10 and 12.



Quick Release fully closed

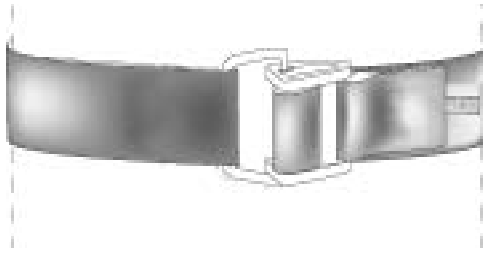

Fitting and Assembly

Mounting Optional Backplate for use with Double Tanks

Backplate Available in: Black Anodized Aluminum p/n 519-BP01A
Stainless Steel p/n 519-BP01S
Titanium p/n 519-BP01T

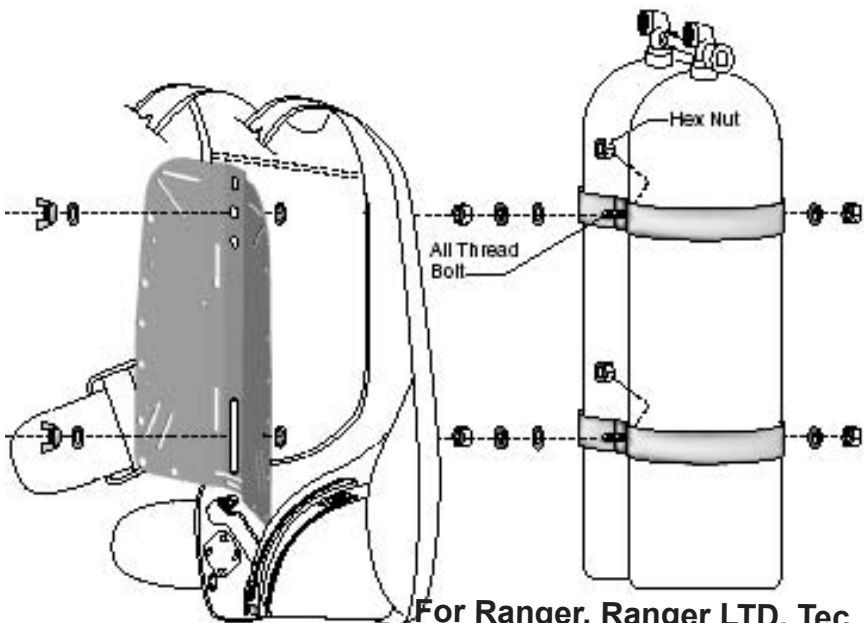

**For Ranger, Ranger LTD, Tec,
Tec-Pac, 911 and SAR BCDs.
May require modification of
built-in Lumbar Pads.**

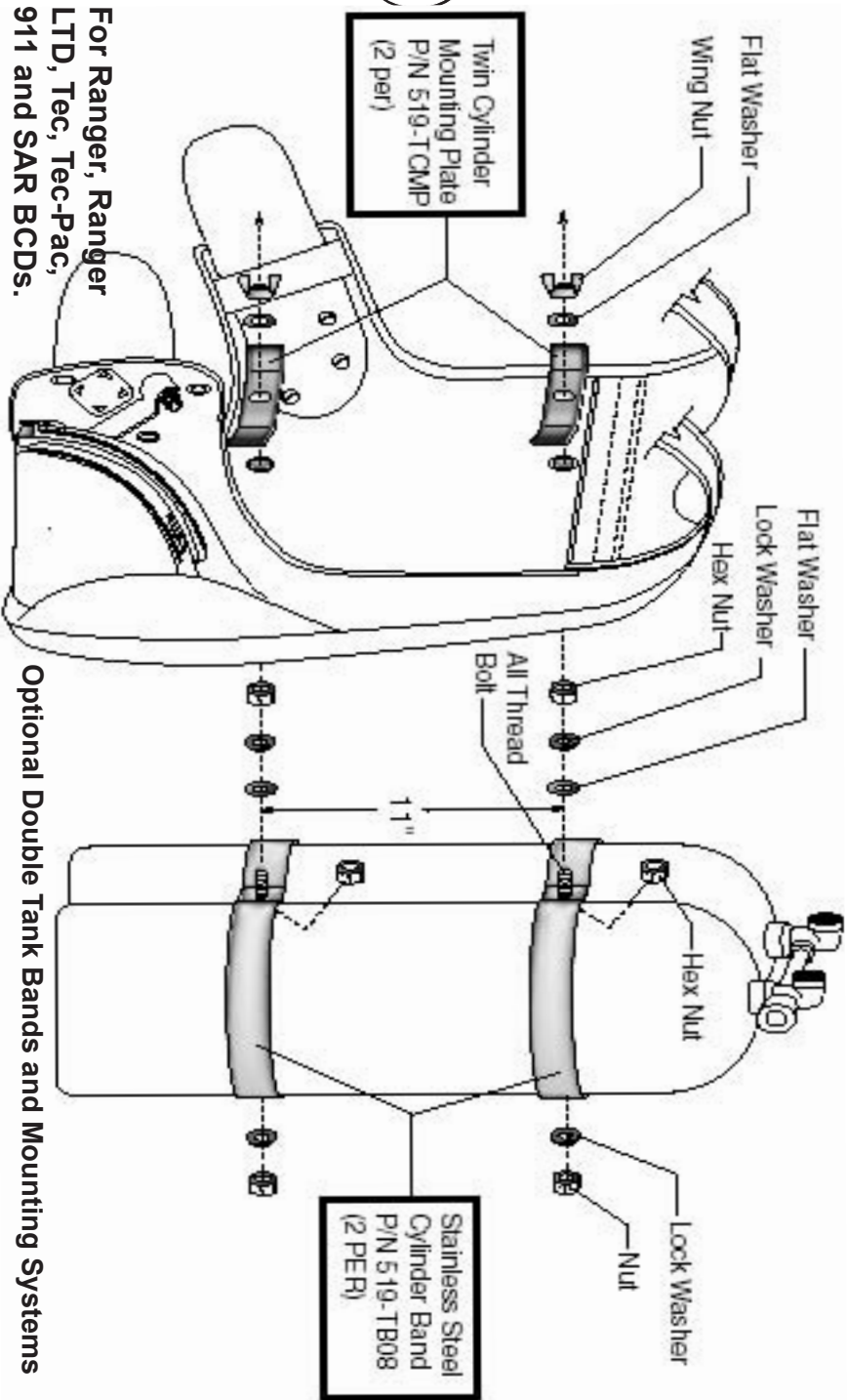

For Ranger, Ranger LTD, Tec, Tec-Pac, 911 and SAR BCDs.

Optional Double Tank Bands and Mounting Systems



Fitting and Assembly

Proper Fit

The Zeagle Personal Fit System allows the diver to size each component of the buoyancy system independently, for a true custom fit. For proper performance, please be sure that your system fits as described below. Put the BC on (before attaching it to a SCUBA cylinder) and adjust the shoulders and waist as follows.

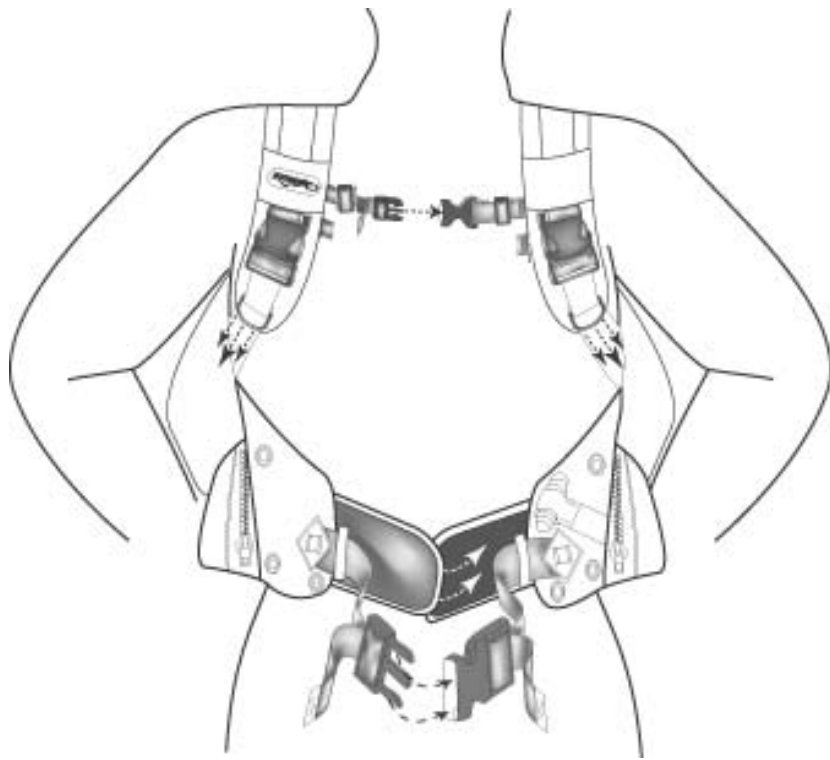

1. Loosen the shoulder straps before donning. Put it on like you would a jacket. If your system is equipped with cummerbund side panels, stretch the elastic by extending each side panel as far as possible before wrapping it around you and fastening the Velcro.

2. The system should be worn low with the bottom of the vest at the top of your hips. Once the cummerbund side panels are secure, fasten the waist strap and tighten it snugly.

3. Fasten the sternum strap. It should be just above the breast line. If you are wearing a dry suit, be sure that the sternum strap does not obstruct the drysuit inflator hose or valve. There are two sets of loops for the sternum strap. If the sternum strap is too high, the strap can be moved to the lower loops.

4. Adjust the shoulder straps.



Pre-dive Assembly and Inspection

WARNING

Adjust the BC so that it does not restrict your breathing. Restriction of normal breathing while wearing your BC could result in injury or death. Before each dive, check all bands, straps, clips, and/or waist panels for proper adjustment.

Over Pressure Valve (OPV)

The over pressure / dump valve is typically located on the lower front of the bladder assembly. Some models have two OP Valves. As its name implies, the OP Valve prevents over inflation of the bladder. The valve automatically releases air when the internal bladder pressure exceeds the valve's spring pressure. The valve will automatically close when the internal bladder pressure becomes less than the valve's spring pressure. This valve may also be used to "dump" air when you are diving, by pulling the knob / string that is attached to the valve. **The OP Valve should be inspected before every dive for proper operation.**

Remote Exhaust Valve (RE Valve)

Your BC may be equipped with a remote exhaust valve. If it is, it is located on the upper left, just behind the shoulder, on the bladder assembly. The RE Valve allows you to "dump" or exhaust air manually as you adjust for neutral buoyancy. The RE Valve operates by simply pulling on the power inflator mechanism and corrugated rubber hose.

IMPORTANT

The RE Valve should be inspected before every dive for proper operation. Also, inspect that both threaded caps on the RE Valve, are tightened securely. The exhaust cap must be tightened a minimum 1/12 turn (3/8 inch) after it first contacts the body. The RE Valve was designed to be serviced. Without proper tightening of these caps, they may loosen over time and be lost.

Power Inflator/ Oral Inflator Mechanism

Your BC may also be equipped with a power inflator/oral inflator mechanism. This unit consists of an Oral Valve Mouthpiece, Oral Valve Button, and Pneumatic Inflation Valve (PIV) and connects directly to the RE Valve via a steel cable (inside the corrugated hose). The PIV operates over a pressure range of 6.5-13.8 bar (95-200 psi). To inflate the BC using the PIV, attach a low pressure hose to the quick disconnect (QD) fitting and depress the PIV button. To inflate the BC using the oral inflator, depress the Oral Valve Dump Button and breathe into the Oral Valve Mouthpiece.

CHECK ALL MECHANISMS BEFORE EVERY DIVE FOR PROPER OPERATION AND LEAKS.



Pre-dive Assembly and Inspection

Weight System Inspection

WARNING

Check to see that weight release system is secure.

Ripcord™ release system - check bottom of weight pockets to be sure they are held closed by the ripcord. If the Ripcord has been pulled, re-thread the system. (Refer to the re-threading section on following page).

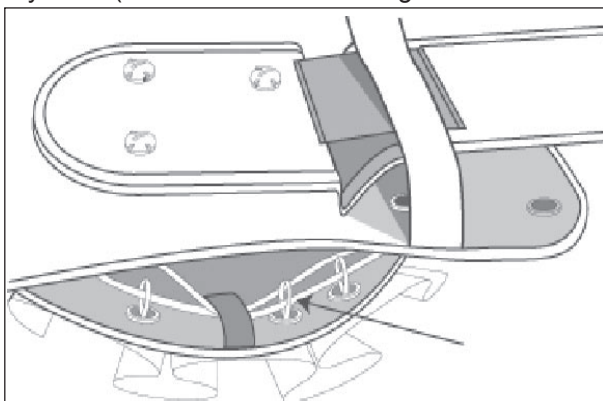

WARNING

Check to see that weight release system is secure.

ZIP Touch™ fastener pocket system - Check to see that the Velcro touch fastener material flap on the bottom of each weight pocket completely overlaps and is secure.

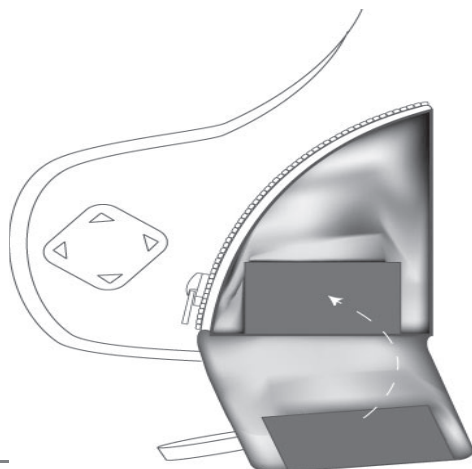



Pre-dive Assembly and Inspection



WARNING

Check to see that weight release system is secure.

Trim Weight™, Pull-Out Pocket™ Velcro Touch Fastener System

- Check to see that the touch fastener material flap on the bottom and sides of each weight pocket completely overlaps and is secure.

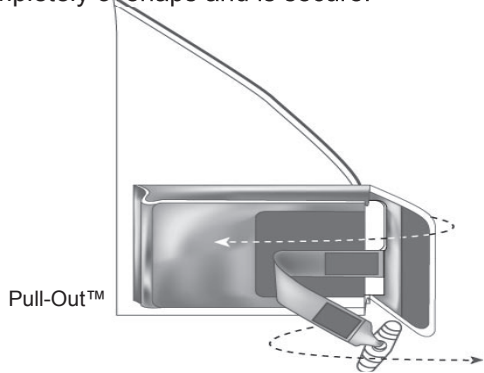
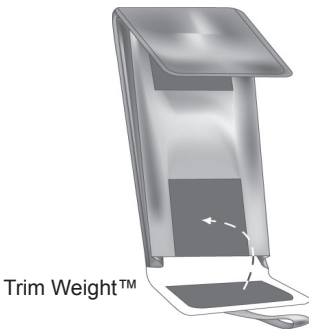

Re-threading The Ripcord™ System

If the Ripcord is not completely secure, re-thread using the following procedure.

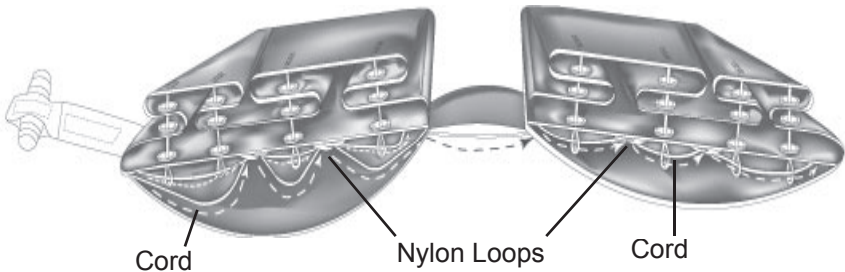

- Return the Ripcord handle to the secure position.
- Pull the cord through for the right side weight pocket.
- Start with the loop closest to the Ripcord handle.
- Each white nylon loop is threaded through three grommets. The cord is then threaded through the end of the white loop.
- Thread the cord under the webbing that is between the grommets.
- Repeat for all nylon loops.
- Finish by pushing the cord between the pocket and the vest.
- Repeat on the opposite pocket.



Pre-dive Assembly and Inspection

Loading the Zeagle Integrated Weight System:

Weights can be loaded after the system is donned as shown, or the weights can be loaded before the system is donned. Considerations include the amount of weight and the distance to enter the water. Ask your buddy for help in either case. To load the weight system:

- Unfasten the buckles securing the bladder assembly winglets to the side of the vest to allow easy access to the weight pockets.
- Load the Ripcord™ or Ziptouch™ pouches through the zippered opening on the pocket top. Be sure the zipper is fully closed after loading.
- Pull-Out™- load the pouch through the Velcro Touch Fastener opening. Close the opening and load the pouch into pocket according to illustration.
- Refasten the buckles securing the bladder winglets to the side of the vest.

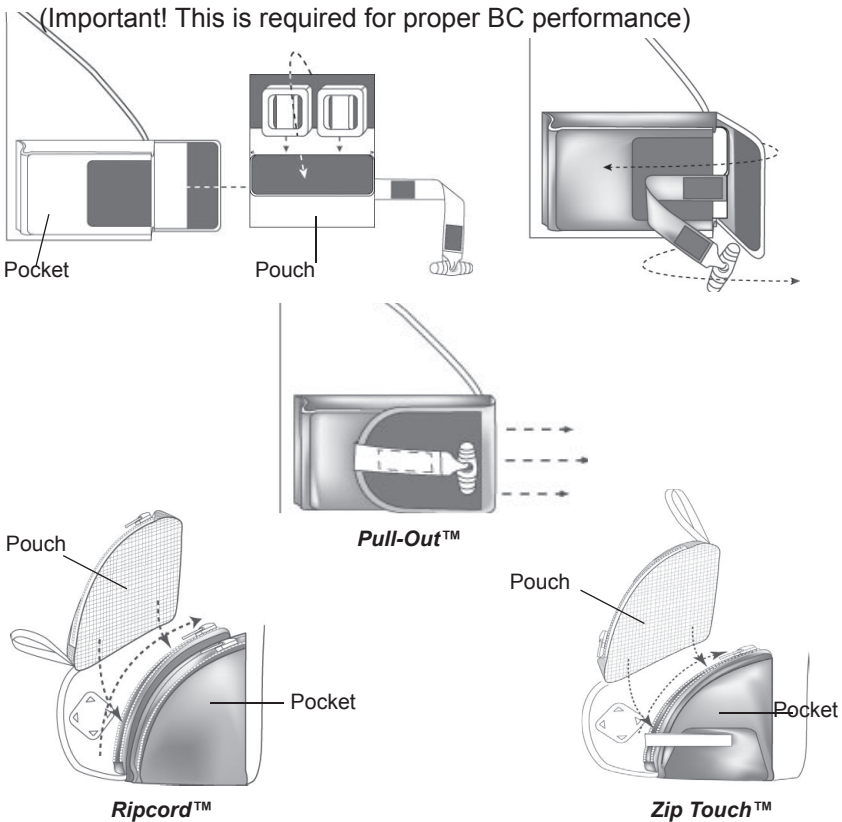



Donning Procedure

 **WARNING**

Diving equipment is heavy! To avoid injury or fatigue and to become familiar with each other's equipment, have your buddy assist you! Take this opportunity to be sure your buddy understands how your weight release works.

Be sure you have read and performed the Proper Fit page in the Fitting and Assembly section of this manual first.

- Open the cylinder band buckles and loosen the bands.
 - Align the system so that the top of the bladder assembly is even with the cylinder valve (slightly higher or lower may be required depending on the diver's size and the type of tank, but this is a good starting point).
 - Make sure that the two sets of bands are in vertical alignment with your tank and not twisted to one side.
 - Pull the bands snug and close the buckles. Secure the loose end of the bands on the Velcro touch fastener.
 - Connect the regulator to the cylinder valve and finish assembling the system per manufacturer's instructions.
 - Be sure you are familiar with the low pressure inflator system on your Zeagle BC. Inflate the system and check for leakage.
 - Weights can be installed in the weight pockets before the BC is donned or after. It may be easier to add your weights after you have the system on to avoid lifting the tank and weights together. Considerations include the amount of weight and the distance to enter the water. Ask your buddy for help in either case.
 - Loosen the shoulder straps.
 - Have your buddy balance the system while you put it on like a jacket.
 - Remember, the system should be worn low with the bottom of the vest at the top of your hips
 - Fasten the side panels and/or the waist band. Extend the cummerbund side panels as far as possible before wrapping them around your body. Be sure to get the waist tight.
 - Fasten the sternum strap and adjust it. If you are wearing a drysuit, be sure that the sternum strap does not obstruct the drysuit inflator hose or valve.
 - Adjust the shoulder straps.
 - Fasten the split saddle strap if your system is so equipped.
-



Diving with the Zeagle System

Pre-Dive Check:

Prior to each dive, always check to make certain your BC has no obvious leaks, by inflating the bladder until the over pressure relief valve vents. Listen for air leaks. If any are found, then service is necessary by an authorized Zeagle technician. Check the Ripcord™, Ziptouch™, or Pull-Out™ weight systems.

(See Illustrations on page 18)

Diving

- Your final buoyancy is primarily affected by your body, your thermal suit, your diving cylinder, and your lead weights. It is **adjusted** with your BCD. Both too little and too much lead ballast can be dangerous. To determine the proper amount of lead ballast weight needed for your system, go (with another diver) to a shallow safe location with the type (fresh or salt) of water you will be diving in later. During the test, wear a **near empty** cylinder of the same size and material you will be using. With a safety diver present, carefully add or remove weights from your system until you float vertically at the surface at eye level with a full breath of air (and a near empty cylinder). The near empty cylinder is important. Many divers weight themselves for a full cylinder, and then have trouble staying down later in the dive as the cylinder gains buoyancy.
- Start your descent by releasing air slowly either through the power inflator by holding the exhaust over your head and pushing on the exhaust button or by pulling gently (approximately 1/2 inch) on the inflator to open the remote exhaust valve on the shoulder if your system is so equipped. **DO NOT USE EXCESSIVE FORCE AS THIS COULD SERIOUSLY DAMAGE THE SYSTEM.** Let out just enough air to start your descent. As you descend and when you reach your desired depth you will need to add air to your Zeagle BC by pressing on the air inlet button of your low pressure inflator to attain "neutral" buoyancy.
- It may be necessary to adjust the waist during the dive due to the compression and expansion of your diving suit.
- You will need to add air to the BC as you descend and exhaust air from the BC as you ascend, to maintain neutral buoyancy throughout your dive.
- When you begin your ascent at the termination of your dive, you must **release air** from your BC either through the exhaust on the inflator or through the remote exhaust. Be sure you are vertical with your left side slightly higher than your right side to vent the BC. You should release air so as to maintain rate of ascent of one foot per second or less. To maintain a safe ascent rate, you must **swim** to the surface. Do not use your BCD to pull you to the surface, as this may result in fast ascents. **Control your Ascent Rate!**
- Inflate your Zeagle BC when you reach the surface to attain a **comfortable** degree of buoyancy and lay back against the tank. Do not Overinflate the BCD.



Emergency Procedures

Emergency Weight Release

WARNING

If you are diving with a buoyant wet or drysuit, be aware that releasing weights at depth should only be done if absolutely necessary (for example, if your drysuit has flooded, making you extremely negative). Without weights, it may be very difficult to control your ascent rate as you near the surface. Weight release at depth should only be done according to the standards set by your certification agency.

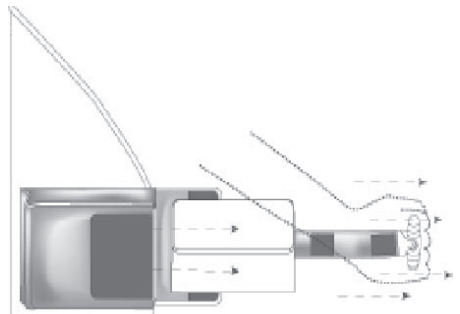
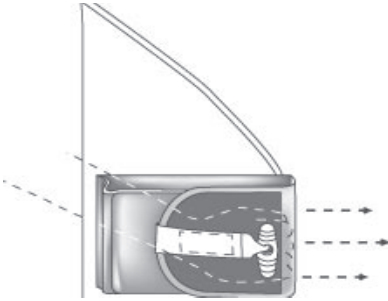

Pull-Out Pocket System

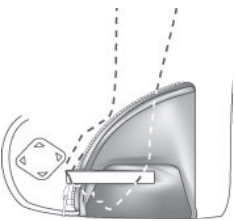

Zip Touch System

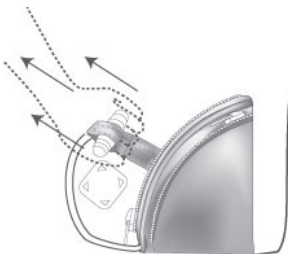
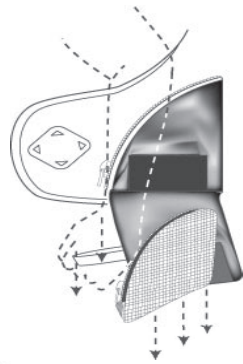

Ripcord System

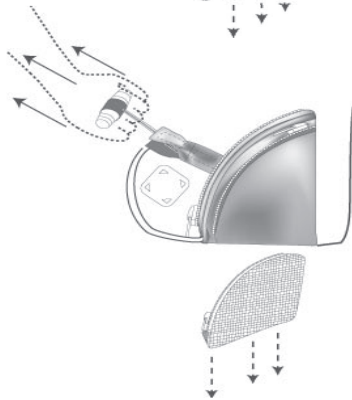



Emergency Procedures

Problem Management

Inflator problem

Inflators may fail due to foreign material in the mechanism, damage from impact by tanks or weights, or other causes. **Practice** the procedures below (in a safe location with your buddy) for your safety.

Inflator fails to operate

Check to see that the low pressure hose is properly connected. Orally inflate the bladder if necessary to establish proper buoyancy.

Inflator valve sticks open

Should the inflator valve stick open, causing an uncontrolled filling of the bladder and/or excessive leakage of air at the inflator, hold exhaust valve open and over your head to vent excess air as you disconnect the low pressure hose from the inflator. Abort the dive.

Exhaust valve or over pressure valve sticks open

If the exhaust valve on the inflator sticks open, hold the inflator in the lowest position possible, to allow the bladder to hold air from that level up. Abort the dive and attempt to swim slowly, 1 ft per 2 sec (0.3 m per 2 seconds), or less, to the surface. Should excessive negative buoyancy be created, your weights may need to be released. Weight release at depth should only be done according to the standards set by your certification agency.

Failure to hold air

If for any reason the system should fail to hold an adequate amount of air to provide necessary buoyancy, abort the dive and attempt to swim slowly, 1 ft per 2 seconds (.3 m per 2 seconds) or less, to the surface. Should excessive negative buoyancy be created, your weights may need to be released. Weight release at depth should only be done according to the standards set by your certification agency.

The above is based on recreational no decompression diving. Decompression divers must have complete redundant systems to handle all problems underwater.

IMPORTANT

If at any time abnormal performance or malfunction is experienced, the system must be serviced by an authorized Zeagle Dealer prior to any further use.



Maintenance

The reliability and correct functioning of your equipment depends on the care it receives.

Post Dive BC Cleaning:

- Rinse the BCD thoroughly with fresh water after each use.
- Rinse the inside of the bladder by holding the exhaust button on the inflator system open and allowing fresh water to partially fill the bladder. “Slosh” the water around to dissolve any salt crystals (salt crystals can damage the bladder over time). Drain the bladder completely and repeat.
- Hang the BCD upside down and allow it to dry while partially inflated. Drain any residual water through the exhaust hose while the BCD is hanging upside down.
- Store the BCD partially inflated in a cool dry place.

Inspection and Service Interval

Your BCD (including the Inflator) should be inspected and maintained by an Authorized Zeagle Dealer at least once a year, and more often if you dive frequently. This is a required action to keep your warranty in effect. There is a Service Record in the back of this manual for the Dealer to record the service performed.

Installation of New Parts/ Alterations



Use of non-factory parts or accessories, or any change to the product not specifically authorized by Zeagle Systems, Inc., or performed by an unauthorized repair facility, may cause improper operation, damage, or leakage of the BC resulting in a loss of buoyancy control or air holding capability. This could result in injury or death, plus will void your warranty. Replace worn or damaged items with approved, factory supplied or specified parts ONLY.



Buoyancy System Accessories



**Pony Bottle
Attachment Kit**
8029HD



Mounts a pony bottle securely to any Zeagle BC



Shot Weight Pouches
8042(12-lb)
8043(20-lb)



BC Pocket
(Clip Closure)
8033CC



Strobe/Flashlight
8036



Full Lumbar Pad
7275F



Zeagle BC Knife
5402



Spare Air Pocket
8055L



Diver Tool Kits
8135 without slate
8135S with slate



EMT Shears
8134



**Removable Rear Mounted
Weight System**
8051Z



Tech Utility Pocket
2 zip compartments
8033

SERVICE RECORD

DATE	SERVICE PERFORMED	SERVICE CENTER	TECHNICIAN #
	Owner Orientation: Dealer Preparation:		

Attach the original or a copy of your purchase receipt to this booklet and store it in a safe place. Your receipt may be needed for warranty validation if you take your BCD to a different Zeagle Dealer for service.

Locating Service and Support

The Dealer that sold you your Buoyancy Compensator will be able to assist you with additional questions regarding product operation, warranty, and service. Go to www.zeagle.com for dealer locations near you.

Your Local Zeagle Dealer:

(Dealer to affix stamp here)



Zeagle Systems, Inc.

**37150 Chancey Road
Zephyrhills, FL. 33541
Phone: (813) 782-5568
Fax: (813) 782-5569
www.zeagle.com**

FOR THOSE PRODUCTS BEARING THE CE MARK:

EC Type Examination by:

SGS Yarsley International Certification Services Limited
SGS House
Portland Road
East Grinstead, West Sussex RH19 4ET
ENGLAND

Notified Body No. 0120